



Development of NASA's Small Fission Power System for Science and Human Exploration

*Marc A. Gibson, Lee S. Mason, and Cheryl L. Bowman
Glenn Research Center, Cleveland, Ohio*

*David I. Poston and Patrick R. McClure
Los Alamos National Laboratory, Los Alamos, New Mexico*

*John Creasy and Chris Robinson
National Security Complex, Oak Ridge, Tennessee*

NASA STI Program . . . in Profile

Since its founding, NASA has been dedicated to the advancement of aeronautics and space science. The NASA Scientific and Technical Information (STI) Program plays a key part in helping NASA maintain this important role.

The NASA STI Program operates under the auspices of the Agency Chief Information Officer. It collects, organizes, provides for archiving, and disseminates NASA's STI. The NASA STI Program provides access to the NASA Technical Report Server—Registered (NTRS Reg) and NASA Technical Report Server—Public (NTRS) thus providing one of the largest collections of aeronautical and space science STI in the world. Results are published in both non-NASA channels and by NASA in the NASA STI Report Series, which includes the following report types:

- TECHNICAL PUBLICATION. Reports of completed research or a major significant phase of research that present the results of NASA programs and include extensive data or theoretical analysis. Includes compilations of significant scientific and technical data and information deemed to be of continuing reference value. NASA counter-part of peer-reviewed formal professional papers, but has less stringent limitations on manuscript length and extent of graphic presentations.
- TECHNICAL MEMORANDUM. Scientific and technical findings that are preliminary or of specialized interest, e.g., “quick-release” reports, working papers, and bibliographies that contain minimal annotation. Does not contain extensive analysis.
- CONTRACTOR REPORT. Scientific and technical findings by NASA-sponsored contractors and grantees.
- CONFERENCE PUBLICATION. Collected papers from scientific and technical conferences, symposia, seminars, or other meetings sponsored or co-sponsored by NASA.
- SPECIAL PUBLICATION. Scientific, technical, or historical information from NASA programs, projects, and missions, often concerned with subjects having substantial public interest.
- TECHNICAL TRANSLATION. English-language translations of foreign scientific and technical material pertinent to NASA's mission.

For more information about the NASA STI program, see the following:

- Access the NASA STI program home page at <http://www.sti.nasa.gov>
- E-mail your question to help@sti.nasa.gov
- Fax your question to the NASA STI Information Desk at 757-864-6500
- Telephone the NASA STI Information Desk at 757-864-9658
- Write to:
NASA STI Program
Mail Stop 148
NASA Langley Research Center
Hampton, VA 23681-2199



Development of NASA's Small Fission Power System for Science and Human Exploration

*Marc A. Gibson, Lee S. Mason, and Cheryl L. Bowman
Glenn Research Center, Cleveland, Ohio*

*David I. Poston and Patrick R. McClure
Los Alamos National Laboratory, Los Alamos, New Mexico*

*John Creasy and Chris Robinson
National Security Complex, Oak Ridge, Tennessee*

Prepared for the
50th Joint Propulsion Conference
cosponsored by AIAA, ASME, SAE, and ASEE
Cleveland, Ohio, July 28–30, 2014

National Aeronautics and
Space Administration

Glenn Research Center
Cleveland, Ohio 44135

This report contains preliminary findings,
subject to revision as analysis proceeds.

Level of Review: This material has been technically reviewed by technical management.

Available from

NASA STI Program
Mail Stop 148
NASA Langley Research Center
Hampton, VA 23681-2199

National Technical Information Service
5285 Port Royal Road
Springfield, VA 22161
703-605-6000

This report is available in electronic form at <http://www.sti.nasa.gov/> and <http://ntrs.nasa.gov/>

Development of NASA's Small Fission Power System for Science and Human Exploration

Marc A. Gibson, Lee S. Mason, and Cheryl L. Bowman
National Aeronautics and Space Administration
Glenn Research Center
Cleveland, Ohio 44135

David I. Poston and Patrick R. McClure
Los Alamos National Laboratory
Los Alamos, New Mexico 87545

John Creasy and Chris Robinson
National Security Complex
Oak Ridge, Tennessee 37830

Abstract

Exploration of our solar system has brought great knowledge to our Nation's scientific and engineering community over the past several decades. As we expand our visions to explore new, more challenging destinations, we must also expand our technology base to support these new missions. NASA's Space Technology Mission Directorate is tasked with developing these technologies for future mission infusion and continues to seek answers to many existing technology gaps. One such technology gap is related to compact power systems (>1 kWe) that provide abundant power for several years where solar energy is unavailable or inadequate. Below 1 kWe, Radioisotope Power Systems have been the workhorse for NASA and will continue, assuming its availability, to be used for lower power applications similar to the successful missions of Voyager, Ulysses, New Horizons, Cassini, and Curiosity. Above 1 kWe, fission power systems (FPSs) become an attractive technology offering a scalable modular design of the reactor, shield, power conversion, and heat transport subsystems. Near-term emphasis has been placed in the 1 to 10 kWe range that lies outside realistic radioisotope power levels and fills a promising technology gap capable of enabling both science and human exploration missions. History has shown that development of space reactors is technically, politically, and financially challenging and requires a new approach to their design and development. A small team of NASA and Department of Energy experts are providing a solution to these enabling FPS technologies starting with the lowest power and most cost-effective reactor series named "Kilopower" that is scalable from approximately 1 to 10 kWe.

Introduction

Over the past five decades numerous space reactors have been designed in the United States with little success in hardware development and no success in flight. As NASA's budget continues to be stretched over a growing mission portfolio, efficient technology development is crucial to building a healthy U.S. space nuclear program capable of producing flight systems. The Kilopower team is challenging the overly expensive technology development process used in past failures by matching a simple reactor to a smart test program with flight hardware as the end success criteria. The development strategy involves a strong test program utilizing existing facilities that will help reduce high-risk components and design assumptions through extensive testing. The program has been carefully planned to match the fidelity of the design to affordable testing capabilities and provide successive steps in the development cycle. The reactor design will advance throughout the test program with a near-term goal of a full-scale nuclear ground test, nicknamed "KRUSTY" (Kilopower Reactor Using Stirling TechnologY), using the flight prototypic highly enriched uranium molybdenum (UMo) core, heat pipe thermal transport

systems, and Stirling power conversion. If successful, the technology demonstration will take approximately 3 years and \$10 million to complete. The fidelity of the design at the end of the 3 years is anticipated to address a major portion of the technical risk associated with a flight unit with minimal invested cost. Figure 1 illustrates the flight concept of a 4-kWt reactor core coupled to a 1-kWe Stirling power conversion system and a 40-kWt core coupled to a 10-kWe conversion assembly. The 1-kWe Kilopower reactor is the baseline design for the nuclear test and will affordably address Kilopower designs ranging from 1 to 10 kWe.

The basic design approach is derived from a 2010 Small Fission Power System Feasibility Study performed by a joint NASA/Department of Energy (DOE) team in response to a request from the National Research Council (NRC) Planetary Science Decadal Survey (Ref. 1). After reviewing options, the team selected a reference concept and evaluated the feasibility for a 10-year flight system development to support future space science missions that exceed radioisotope power system capabilities or require too much ^{238}Pu fuel. The reference concept defined in the 2010 study is similar to the current Kilopower concept, sharing the cast UMo fuel form, BeO reflector, and Na heat pipes. The baseline reactor thermal power level for the 2010 concept was 13 kWt, allowing a thermoelectric power system option at 1 kWe (Ref. 2) or a Stirling power system option at 3 kWe (Ref. 3).

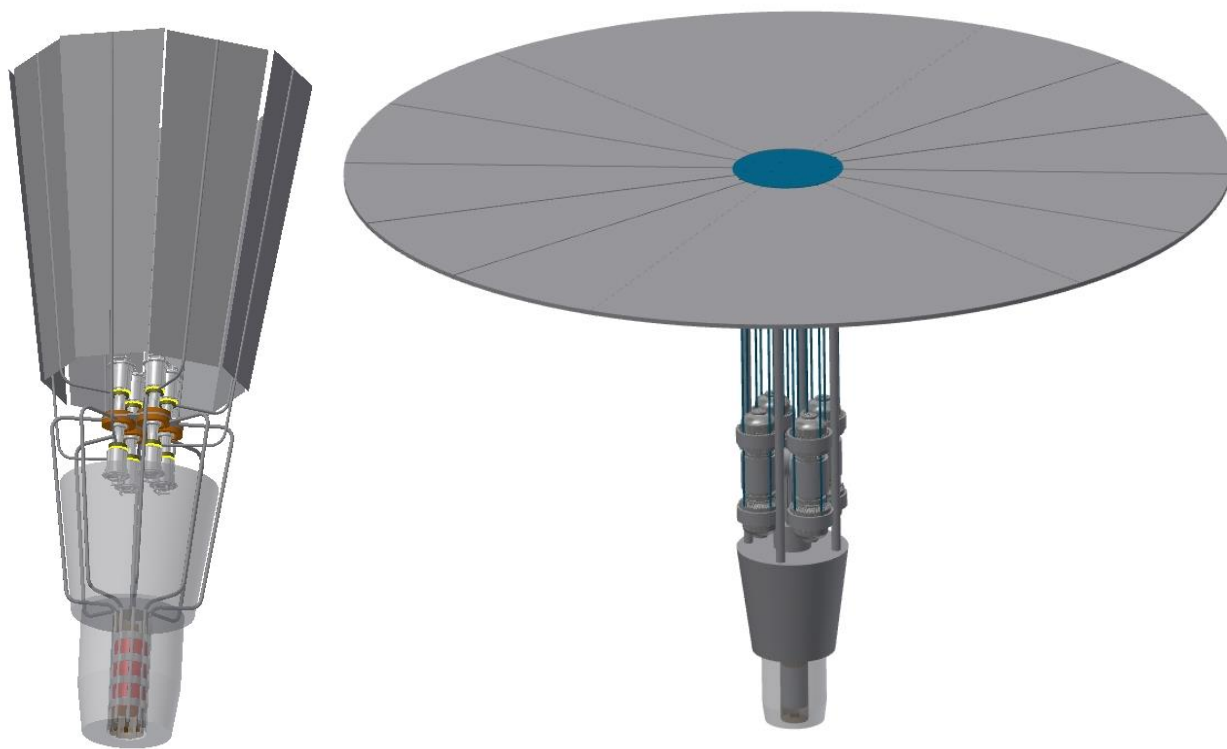

Figure 1.—The 1-kWe (left) and 10-kWe (right) Kilopower systems.

System Design

Reactor

The Los Alamos National Laboratory is leading the design of the reactor, reflector, and shield that will be demonstrated in the full-scale nuclear test. The Y-12 National Security Complex is leading the material development and manufacturing of the uranium alloy core and will verify fuel selection through early material testing and manufacturing trials leading up to the full-scale fabrication. As part of the development phase, there will be numerous tests to validate the design and material selections with expected iterations leading up to the final design. A solid cast UMo alloy core has been selected as the fuel because of an existing material database, simple reactor construction and operation, and most importantly, the existing infrastructure and production capabilities at Y-12 National Security Complex. The solid core works well with lower power reactors because of negligible fuel burnup and volume swelling issues that can challenge higher power reactors, which would typically incorporate clad pin-type fuel (Ref. 4). The solid core design provides sufficient thermal power while reducing the fuel, radial reflector, and shadow shield geometry and mass, giving the total system a higher specific power (W/kg) than other fuel forms. The baseline material for the core has been chosen to be 93 percent highly enriched U235 alloyed with 7 percent Mo by weight, and is expected to produce an optimum balance between neutronic, thermal, and metallurgical properties (Ref. 5). Figure 2 shows the current Los Alamos National Laboratory design of a 4-kWt flight core, which provides 1 kWe with Stirling power conversion.

Beryllium oxide has been selected as the radial reflector material for its high neutron reflectance throughout the required temperature and energy spectrum as well as its mechanical and thermal properties. The reflector design is monolithic and does not incorporate control drums typical of higher power reactors, highlighting another significant and simplified design feature. For criticality safety throughout Assembly Test and Launch Operations (ATLO), only a single control rod of B₄C is needed in the center of the core to keep k_{eff} at a safe level during all expected operations and hypothetical accidents. When the reactor reaches its startup location in space or on the surface of another planet, a control mechanism will slowly remove the poison control rod and allow the reactor to start up. This benefit of controlled startup at the mission destination allows beginning of mission (BOM) power levels and overall power system life expectancy to be directly coupled to mission timeline requirements. The flight system could utilize a number of control rod options that could be specifically tailored to mission requirements. For instance, the simplest control rod design, as baselined, would perform only one movement at the

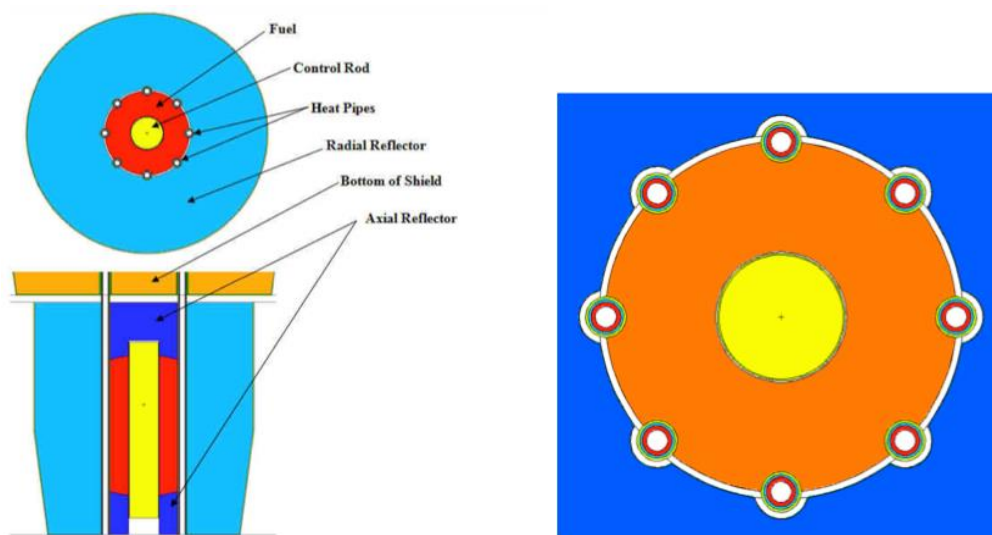

Figure 2.—Flight design of the Kilopower 4-kWt core and reflector assembly.

beginning of the mission allowing the reactor to start up and load follow the power conversion system. This method allows the natural degradation of the core temperature as fuel is spent and neutronic behavior changes over time. Conservative thermal degradation of the 4-kWt core using this method are estimated to be 3 K/year with 0.1 percent fuel burnup over 15 years. An alternative approach is to use an active control rod that adds reactivity as needed throughout the mission to keep the reactor temperature and power constant. Using active control, the reactor can provide constant power for several hundred years at the 4 kWt level due to very little fuel burnup and needed reactivity insertion. These simple control rod and startup methods are an important design feature needed for missions that may require the reactor to start up under minimum power at a location where solar energy is limited and battery power is necessary. Initial estimates of the required power for startup is 1 amp hr at 28 V of direct current.

Heat Transport and Power Conversion

Thermal energy from the core is transported to the power convertors via sodium heat pipes. Heat generated from the fission reactions is conducted through the core and into the heat pipe evaporator and vaporizes the sodium liquid. The sodium vapor travels up the heat pipe where it can be accepted by the Stirling convertors at the condenser interface. As the sodium vapor releases its latent heat and condenses back to the liquid phase, the wick pumps it back to the evaporator where the cycle continues. Alloy 230 is the baseline envelope material for the heat pipes because of its known compatibility and prior experience with sodium as well as its high temperature strength and creep resistance. This passive thermal transport operates solely on thermal energy and requires no electrical power for pumping. This is an important design feature, which reduces the parasitic losses of the power system and simplifies system startup and control.

High-efficiency free-piston Stirling convertors have been baselined for the initial designs to increase system performance and provide high specific power. Their use benefits from existing flight development of the Sunpower, Inc., 80-We Advanced Stirling Convertor (ASC) as well as recent successful technology demonstrations of both 1- and 6-kWe convertors developed by Sunpower, Inc., for NASA under the current Nuclear Systems Program. The Stirling engine heat acceptor is conductively coupled to the sodium heat pipe condenser and uses the thermal energy from the reactor to thermodynamically drive the power piston and linear alternator. The Stirling convertors in both the 1- and 10-kWe Kilopower designs are arranged in the vertical dual-opposed configuration allowing easy power scaling while minimizing the shield half angle and mass. Thermoelectric conversion has been studied as an alternate power conversion technology that offers simplicity and additional redundancy but requires significantly more thermal power from the reactor due to its lower efficiency (Ref. 2). NASA studies are currently looking at these two power conversion options for future development and mission use. The preliminary baseline design (Fig. 1) uses eight 125-We ASC-style convertors in a dual-opposed configuration with mating hot ends. Coupling the hot ends of all eight convertors is a conduction plate that allows redundant heat paths in the event of a heat pipe or convertor failure. This hot-end assembly increases reliability but also reduces mass using a unified insulation package and fewer components. Future Stirling designs will likely incorporate a shared expansion space between engine pairs similar to the current 6-kWe Sunpower, Inc., design (Ref. 6).

The Stirling engines must reject their waste heat to space at the optimum temperature in order to establish a balance between the conversion efficiency and radiator mass. This optimum temperature is not equal for the 1- and 10-kWe systems but does fit well within the operating range for water-based heat pipes. Titanium-water heat pipes are baselined for the Kilopower systems and have already been through a significant development cycle with numerous successful designs and tests. The titanium-water heat pipes will transfer the waste heat from the Stirling engines to a radiator fin where it can then be rejected to space.

Mass and Performance Scaling of Kilopower Systems

Preliminary mass estimates were generated for Kilopower systems from 1 to 10 kWe, assuming the same basic reactor design parameters defined in the 2010 NRC feasibility study. The results are presented in Table I. The 1-kWe system allows the heat pipes to be clamped to the outside perimeter of the core, while the larger systems will require the heat pipes to be inserted into the core. Increasing power output requires a slightly larger core and more heat pipes, but no major changes to the basic design approach. The radiator area is based on one-sided heat rejection to a 200 K thermal sink with 10 percent area margin. The systems could employ fixed radiators for planetary spacecraft applications or deployable radiators for Mars surface applications. The stowed dimensions are provided for both options. The mass breakouts are shown for the reactor, shield, and balance of plant. As indicated, the system specific power improves with increasing power level from about 2.5 W/kg at 1 kWe to 6.5 W/kg at 10 kWe.

The system concepts are meant to support both science and human exploration uses (Ref. 7). For science, a number of mission concepts were studied during the NRC Planetary Science Decadal Survey with projected power requirements greater than 500 W (Ref. 8). These missions may include orbiters, landers, multiple science targets, expanded instrument suites, in situ data analysis, high-rate communications, and/or electric propulsion. Human outpost missions to the Moon and Mars have generally required tens of kilowatts to accommodate landers, habitats, In-Situ Resource Utilization (ISRU) plants, rover recharging, communication relays, and science packages. Until recently, the preferred approach was to deliver a large, centralized 40-kWe fission power plant that could meet the mission requirements with margin for growth. The drawback was the large landed mass, complex installation, and lack of system-level redundancy. The 1- to 10-kWe fission power option could be used for human precursor missions to demonstrate ISRU production or on human outpost missions where compact packaging, modularity, and redundancy are favored over growth capacity. An additional application for the small fission system that is being considered for Mars surface missions is to provide a portable utility pallet for remote charging of long-distance piloted rovers.

TABLE I.—KILOPOWER SYSTEM OPTIONS

User Power, kWe	1	3	5	7	10
Power System Characteristics					
Reactor thermal power, kWt	4.3	13.0	21.7	30.3	43.3
Radiator area, m ²	3.2	9.6	13.5	17.1	20.0
Stowed diameter, m	1.1	1.2	1.3	1.4	1.5
Stowed height (with fixed radiator), m	3.0	4.9	5.9	6.7	7.3
Stowed height (with deployable radiator), m	N/A	2.2	2.7	3.0	3.3
Mass Summary, kg					
Reactor (UMo core, BeO reflector, Na heat pipes)	136	175	198	215	235
Shield (LiH/W, 25 krad and 10 ¹¹ n/cm ² at 10 m separation)	148	272	364	443	547
Balance-of-plant (Stirling engines, radiator, electric controls, structure)	122	304	449	589	763
Power system, kg	406	751	1011	1246	1544
Specific power, W/kg	2.5	4.0	4.9	5.6	6.5

The Development Program

Early demonstration of the Kilopower technology was proven with the DUFF (Demonstration Using Flattop Fission) experiment in 2011 (Refs. 9 and 10). This test not only showed that nuclear testing of space reactors and their subcomponents can be affordably tested but that there are existing nuclear facilities that can be utilized for development programs (Ref. 11). This proof-of-concept test successfully showed that reactors could be coupled to Stirling power convertors via heat pipes and produce electricity. Building on the DUFF experiment, the Kilopower team has planned a follow-on 3-year development program that is designed to reduce the technical risk associated with the flight unit by addressing many first- and second-order design uncertainties. The 3-year program is expected to start at the beginning of NASA fiscal year 2015 and end with the KRUSTY test by the start of fiscal year 2018. In order to complete the program, many tests will be performed to determine if the preliminary design will function as expected with the understanding that modifications will be necessary to evolve towards the final design. These tests will include material testing, simple thermal mockup tests, higher fidelity component and system tests, and end with the full-scale nuclear test. Using this strategy, early first-order design flaws will be exposed with little investment and plenty of time for design modifications. All mechanical, thermal, and power conversion systems will be completely verified before nuclear testing is commenced.

Material Testing and Fabrication

Neutronic worth is a key driver for selecting a reactor fuel. Chemical and structural stability are, however, very important design factors as well. It cannot be overemphasized that the fuel selection trade space is greatly expanded by designing the fission system to a very low fuel burnup. The gas generation and fuel swelling that result from advanced radiological stages are crucial drivers in most fuel systems but are essentially nonfactors in the design trade-space discussed here. Fabricability, structural stability, chemical stability as well as neutronic worth were the discriminators used for fuel selection in this design concept. Uranium oxides or uranium nitrides were not selected since the additional volume stability is not needed in low burnup applications. The selection of an UMo alloy over uranium with low alloying additions was made to take advantage of the higher temperature strength, wider range of microstructural stability, and the relatively larger physical property data associated with UMo alloys. The Y-12 National Security Complex, NASA Glenn, and Los Alamos National Laboratory have conducted extensive reviews of data collected for the past five decades regarding UMo fuel properties. The 2009 UMo Fuels Handbook (Ref. 12) provides the thermophysical and much of the mechanical property data required for conceptual design of the compact fission power system (FPS). Absent from the fuels handbook is time-dependent mechanical property data, or creep data, which will be needed for this design but is not relevant in typical fuel pellet systems. Scrutiny of older literature suggests that, although the creep strength of UMo alloys is very low at these temperatures, it will be sufficient for this design (Ref. 13). These material selection assumptions will be verified by casting and testing a lot of prototypic depleted UMo rods. Samples will be tested for compressive creep strength, tensile creep strength, impact excitation modulus, and diffusion rates relative to pure molybdenum after characterizing the chemistry and grain size of the rod.

Thermal Prototypes

Each of the Kilopower components will start with thermal testing to verify analytical models and provide test and assembly knowledge that will be useful leading up to the nuclear demonstration. Starting with the reactor core, the heat transfer mechanisms associated with the thermal coupling and temperature drop from the core to the sodium heat pipe evaporator will be demonstrated using a full-scale stainless steel 316L core, a custom graphite heater, eight alloy 230/sodium heat pipes, 316L core containment can, mock axial reflectors, and several heat pipe clamping designs. This early prototype will address several first-order design features that can easily be modified to improve performance and eventually be

downselected to carry forward through the test program. The assembly has been specially designed to not only test heat transfer and mechanical coupling but will also verify assembly operations for KRUSTY integration. Figure 3 shows the thermal prototype assembly and the individual components intended for early testing. The 316L stainless steel was chosen as the surrogate material for many of the components as a cost-effective way to develop early material creep models that could verify modeling tools and creep behavior of the design. The surrogate material physical properties are very well documented and are similar enough to many of the published UMo alloy properties that results should be useful on numerous first-order effects. At the conclusion of the material and thermal prototype tests, a preliminary design review will be held to determine if the design is ready to move forward to casting a depleted UMo core for further nonnuclear testing. The thermal prototype testing will verify the following:

- (1) High-temperature creep modeling using known 316L material properties
- (2) Heater design and thermal behavior at nominal Kilopower operating temperatures and power levels
- (3) Core to heat pipe contact resistance and thermal performance
- (4) MLI (Multi-Layer Insulation) assembly and thermal performance
- (5) Sodium heat pipe performance using gas calorimetry
- (6) Heat pipe to core clamping mechanisms
- (7) Core containment can geometry and mechanical design
- (8) Assembly processes for KRUSTY and ATLO

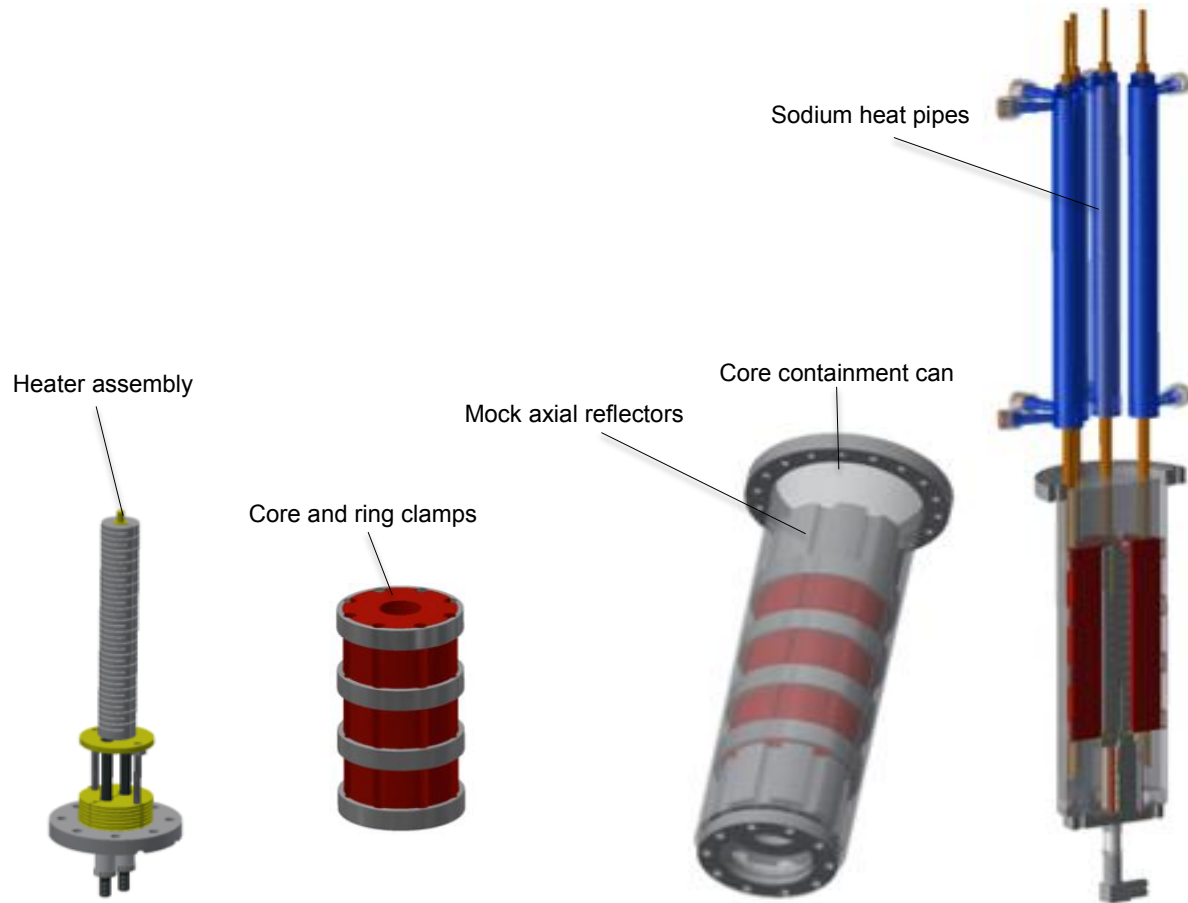

Figure 3.—Thermal prototype assembly and test components.

Stirling Power Conversion and Sodium Heat Pipe Testing

The ASC power conversion units from the Advanced Stirling Radioisotope Generator (ASRG) program will be used for initial power conversion testing starting in fiscal year 2015. Two convertors will first be tested separately to reverify individual performance followed by coupling them as a pair to the Kilopower hot-end conduction plate and sodium heat pipes. Internal modifications to the convertors are expected to boost performance by 20 percent for Kilopower testing and take advantage of the higher power fission heat source. With eight sodium heat pipes and only two convertors, the remaining convertor assemblies will be replaced with thermal simulators to mimic the response of the Stirling convertors. The conduction plate will be the coupling mechanism between the eight heat pipes, six thermal simulators, and two Stirling convertors. The assembly will initially be tested in vacuum with the stainless steel core to verify system performance and thermal integrity. Figure 4 illustrates the sodium heat pipe array, hot-end conduction plate, and Stirling convertors/simulators. This test will address the following:

- (1) System-level integration and assembly processes
- (2) Steady-state and transient system performance
- (3) Total conversion efficiency including thermal losses
- (4) Flight prototypic sodium heat pipe performance
- (5) System response and mechanical integrity to induced heat pipe failure
- (6) System response to simulated convertor failure

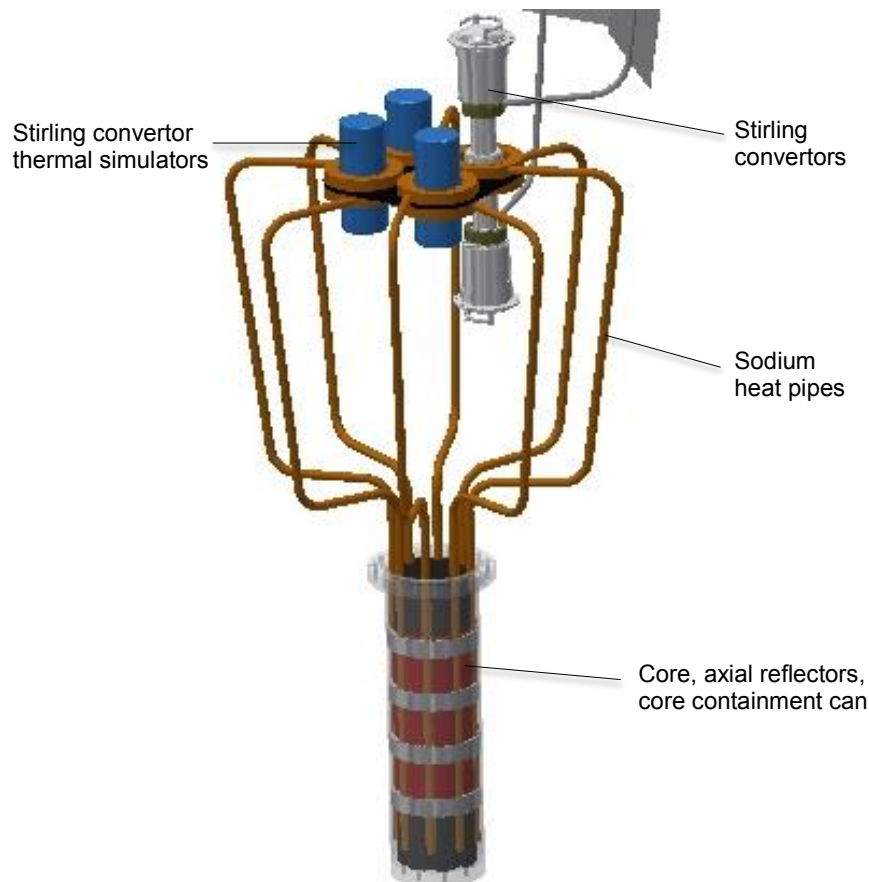

Figure 4.—Kilopower Assembly Test with core, sodium heat pipes, hot-end conduction plate, Stirling convertors, and Stirling thermal simulators.

Depleted UMo Core

Once the preliminary design review is complete, the engineering drawings will be released to produce a depleted UMo core at the Y-12 National Security Complex. Y-12 will build the core to print and ship to the NASA Glenn Research Center where further testing will take place. At the time of delivery, the Kilopower system will have been fully checked out and ready for integration with the depleted uranium core. This test assembly is identical to the Stirling power conversion and sodium heat pipe configuration in Figure 4 and will further the design fidelity by verifying:

- (1) The UMo interface requirements between the heat pipes, insulation, and clamping mechanisms
- (2) Mechanical design integrity during multiple thermal cycles and potential core deformation
- (3) Thermal expansion of the core and its effects on the system
- (4) Material creep of the UMo core under induced design stresses
- (5) Diffusion of the UMo with interface materials
- (6) Thermal vacuum acceptance criteria

Highly Enriched UMo Core and the KRUSTY Test

At completion of the NASA thermal vacuum testing of the depleted uranium core, a final design review will be held to determine if the highly enriched uranium core is ready to begin fabrication. This final design review will accumulate all design revisions throughout the testing program and release the final design drawings to Y-12 National Security Complex for fabrication. When complete, the highly enriched uranium core will be shipped to the Device Assembly Facility (DAF) where it will integrate into the test assembly at the proper time. The full-scale nuclear testing will be performed with the Comet criticality machine at the DAF. The flight prototypic assembly for the KRUSTY test will be identical to the depleted uranium core test leaving only the nuclear design to be verified. Figure 5 illustrates the integrated test assembly with Comet depicting the two extreme reflector positions using the lift table. Comet will make the test assembly go critical by raising the radial reflector around the core and provide the necessary reactivity to create the 4-kWt steady-state thermal power. The test assembly will incorporate a custom vacuum chamber specifically designed to fit on top of Comet and provide the relevant space environment throughout the nuclear testing. The KRUSTY test will verify and/or demonstrate:

- (1) Reactor startup operations
- (2) Excess reactivity needed to meet Kilopower thermal power and temperature requirements
- (3) Integral nuclear cross sections and temperature dependence
- (4) Reactor load following to Stirling convertor demands
- (5) ATLO assembly procedures
- (6) Steady state and transient differences between electrical and nuclear heat sources
- (7) Temperature feedback mechanisms and dynamic response
- (8) Operational stability for follow-on engineering unit nuclear tests
- (9) Nuclear design tools such as FRINK and MRFLOW

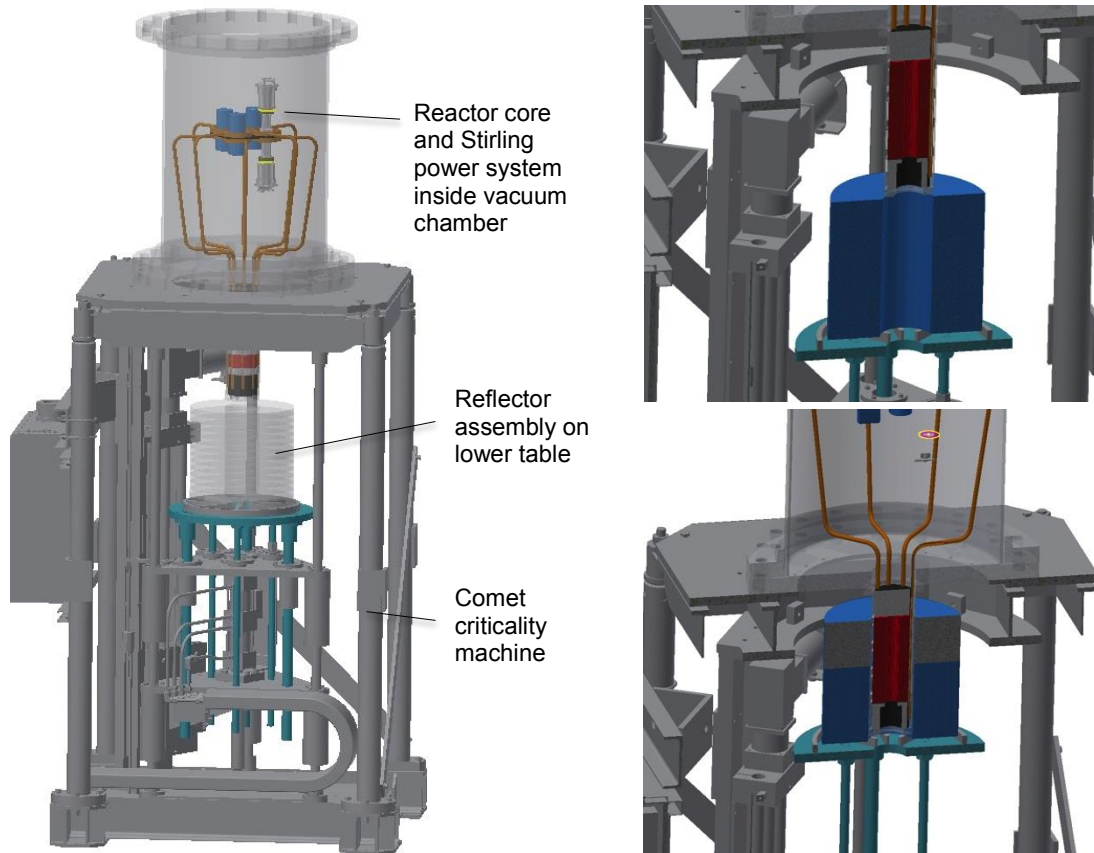

Figure 5.—KRUSTY test assembly integrated with the Comet criticality machine.

Conclusion

Developing a small fission power system for NASA’s science and human exploration is an endeavor worth taking with potential to open up a new class of missions not currently achievable with radioisotope and solar power sources. An affordable approach to addressing many engineering risks of a future flight development program have been proposed to take approximately 3 years and \$10 million using a test plan that progresses through increasing levels of hardware fidelity leading up to a full nuclear ground test nicknamed “KRUSTY” (Kilopower Reactor Using Stirling TechnologY). This development project of Kilopower will provide extensive science and engineering data not attained in the last five decades of U.S. space reactor programs.

Starting with the lower power 4-kWt reactor core for the first nuclear demonstration is extremely important to keeping development costs at an affordable level. Nuclear testing costs are directly proportional to reactor thermal power and the 4-kWt design allows the testing to take place at existing facilities under current regulations and licensing at the Nevada test site. By design, the lower power demonstration offers a subscale test of a 10 kWe capability, adding considerable value to both science and human exploration needs and paving the way for future higher power systems. Successful nuclear testing of the Kilopower reactor will help fill the existing technology gap of compact power systems in the 1 to 10 kWe range enabling new higher power NASA science and human exploration missions.

References

1. Committee on the Planetary Science Decadal Survey: Vision and Voyages for Planetary Science in the Decade 2013–2022. National Research Council, The National Academies Press, Washington DC, 2011.
2. Mason, L., et al.: A Small Fission Power System for NASA Planetary Science Missions. NASA/TM—2011-217099, 2011.
3. Mason, L.; and Carmichael, C.: A Small Fission Power System With Stirling Power Conversion for NASA Science Missions. NASA/TM—2011-217204, 2011.
4. Poston, D.I., et al.: Notional Design of the Kilowatt Space Reactor. NETS–2014–2007, 2014.
5. Creasy, J.; and Bowman, C.: Fuel Selection and Development for Small Fission Power Systems. NETS–2014–2006, 2014.
6. Geng, S.M., et al.: Development of a 12 kWe Stirling Power Conversion Unit for Fission Power Systems-Status Update. NETS–2014–2004, 2014.
7. Mason, L.; Gibson, M.A.; and Poston, D.I.: Kilowatt-Class Fission Power Systems for Science and Human Precursor Missions. NASA/TM—2013-216541, 2013.
8. Planetary Science Decadal Survey Mission & Technology Studies. The National Academies Press, Washington DC, 2015. http://sites.nationalacademies.org/SSB/SSB_059331 Accessed Feb. 17, 2015.
9. Poston, D.I., et al.: The DUFF Experiment-What was Learned? NETS–2013–6967, 2013.
10. Gibson, M.A., et al.: Heat Pipe Powered Stirling Conversion for the Demonstration Using Flattop Fission (DUFF) Test. NASA/TM—2013-216542, 2013.
11. McClure, P.R.; and Holt, J.L.: The Use of the Nevada National Security Site as a Reactor Test Center. NETS–2014, NASA Stennis Space Center, MS, 2014.
12. Rest, J., et al.: UMo Fuels Handbook. ANL-09/31, 2009.
13. Nichols, R.W.: Uranium and its Alloys. Nuclear Engineering, 1957, pp. 355–365.

